Adroit[®]
DV96 (Integral CO₂ Sensor)

Instruction Manual



Adroit®

DV96 (Integral CO₂ Sensor)

CONTENTS

1. INTRODUCTION	4
<ul style="list-style-type: none">• Main parts of the ventilation unit• System description• General safety instructions• Adroit digital controller• Starting up and shutting down the unit	
2. INSTALLATION	10
<ul style="list-style-type: none">• Installation and mounting• Airflow measuring tubes• Dimensions and duct outlets• Condensing water outlet	
3. MAINTENANCE	14
<ul style="list-style-type: none">• Filters• Heat recovery cell• Fans• Condensate drain• Troubleshooting	
4. TECHNICAL SPECIFICATIONS	20
<ul style="list-style-type: none">• Technical specifications, input powers, air volumes, sound values, fan curves, dimensions, duct outlets and measurement points• Internal electrical connection• External electrical connection	
5. CERTIFICATE OF CONFORMITY	25
6. EXPLODED VIEW AND PARTS LIST	27
7. COMMISSIONING THE SYSTEM	28
8. WARRANTY	28

**NOTE:**

You can sign into your Adroit account at: www.airflowadroitcontrol.com

MAIN PARTS OF THE VENTILATION UNIT

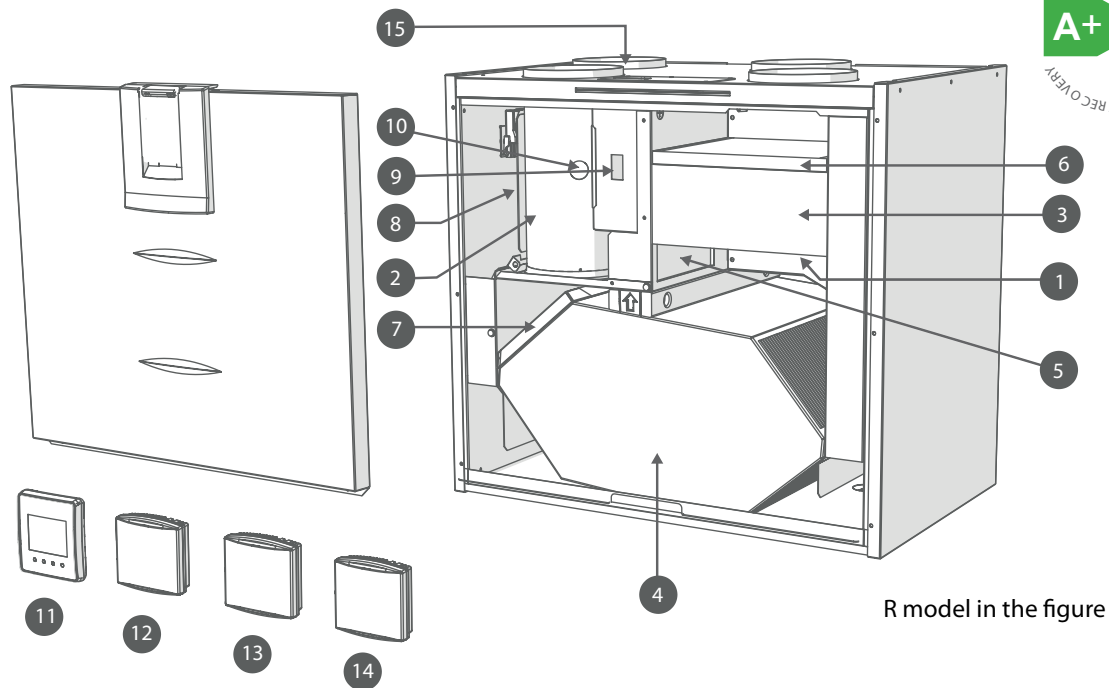

R model in the figure

- | | |
|--|---|
|  Extract air fan (behind the protective cover) 1 |  Electrical safety cut off switch 9 |
|  Supply air fan (behind metal duct pipe) 2 |  Internal humidity sensor 10 |
|  Fine filter for supply air 3 |  Internal carbon dioxide sensor 10 |
|  Heat recovery cell 4 |  Digital Controller (optional) 11 |
|  Heat Recovery cell bypass damper 5 |  Humidity sensor (optional) 12 |
|  Coarse filter for supply air 6 |  Carbon dioxide sensor (optional) 13 |
|  Coarse filter for extract air 7 |  VOC sensor (optional) 14 |
|  Post-heater (Optional) (behind the extract air duct) 8 |  Cable gland 15 |

NOTE For more detailed instructions, go to www.airflow.com

INTRODUCTION

Adroit®
DV96 (Integral CO₂ Sensor)

SYSTEM DESCRIPTION

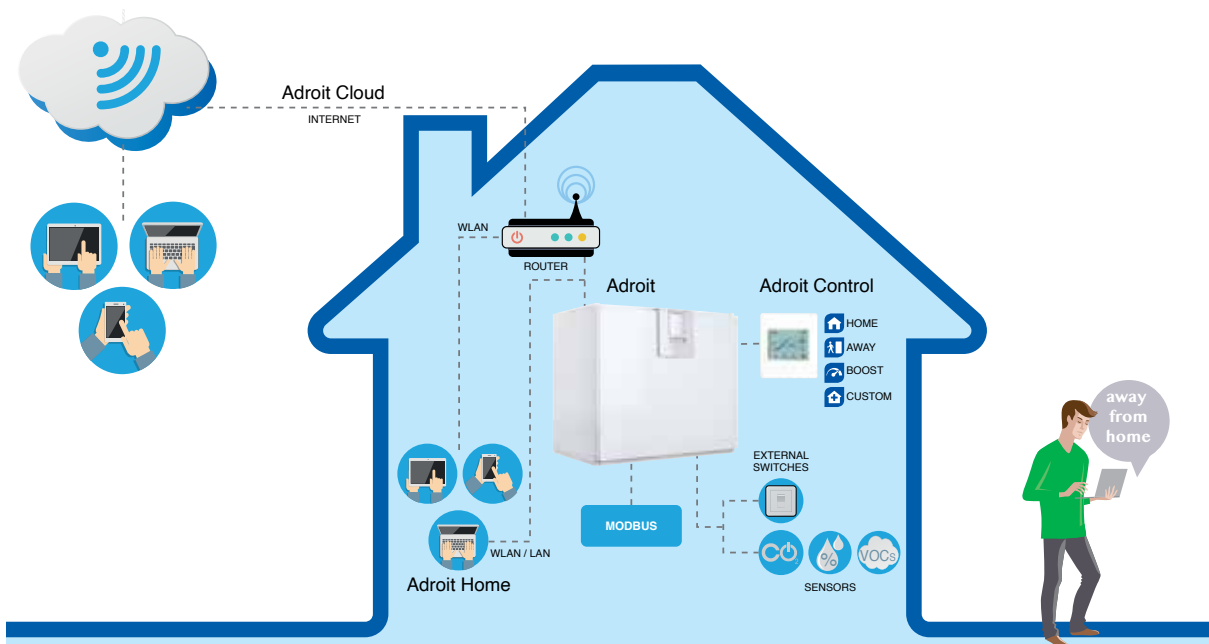

CONNECTING WITH ADROIT HOME

1. Connect Adroit unit to the mains.
2. Connect one end of the network cable (RJ-45) to computer and the other end to network connector on the Adroit unit.
3. Select on your computer: Start → Computer → Network
4. Double click on the Airflow icon. Under Other Devices, double click the device with a name starting "airflow" e.g. "airflowB057A632Af42" (this is the MAC address).
5. Now you are connected to the Adroit Home service, you are able to control the Adroit unit.

REGISTERING TO THE ADROIT CLOUD

1. Connect with Adroit Home (instruction above).
2. Select Settings.
3. Press connect button in Adroit Cloud Service section.
4. Registration Page is now opened.
5. Enter the following information
 - a. Device name- enter the desired name for the device
 - b. User name
 - c. E-mail address
 - d. Password
6. Press the create account button.
7. An e-mail with your log-in details will be sent to the e-mail given during the registration process.
8. A verification e-mail will be sent to the e-mail address given during the registration process.
9. Click on the link given in this e-mail to verify your e-mail address.
10. You are now connected to the Adroit Cloud.



NOTE

The Adroit unit can also be connected by network cable to a router. In this case the Adroit unit can be controlled via your laptop, tablet, smartphone etc using a network created by the router.



NOTE

Following requirements:
Firefox, version 31 or higher
Opera, version 25 or higher
Chrome, version 31 or higher
Safari, version 7 or higher
The latest browser versions on mobile devices.

Adroit®

DV96 (Integral CO₂ Sensor)

INTRODUCTION

GENERAL INFORMATION ABOUT THE UNIT

- DV96 can be equipped with an optional electric post heater (900W)
- In the DV96 Adroit unit, there is a sealing tape at the bottom of the heat recovery cell.

Mounting options:

- Unit supplied with wall mounting bracket; optional ceiling mount available. These units can also be floor mounted if raised up to give clearance for condensate drain.



IMPORTANT

For further information, go to www.airflow.com

GENERAL SAFETY INSTRUCTIONS

For safe and proper handling, it is necessary to know the basic safety regulations and the intended usage of the ventilation system. Read this manual before operating the ventilation unit. Keep this manual for later use. In case of loss, you can download the manual from our website. This user manual contains all important tips for operating the system safely. This user manual must be observed by all persons who operate and maintain the ventilation system. Furthermore, observe all local health and electrical safety regulations.

INTENDED USE

















All Adroit units have been designed to provide appropriate and continuous ventilation, in such a way that people and structures will remain healthy.

INSTALLATION

Installation and setup should be carried out by competent person. Electrical installations and connections must only be carried out by an electrician and according to the local regulations.

ADROIT DIGITAL CONTROLLER

Note: Option description can be set by the button below the displayed image.

DISPLAYED IMAGE	OPTION DESCRIPTION
	Change profile. Allows you to scroll through the ventilation profiles.
	Profile Information. Allows you to view the currently active profile information.
	Temperature. Displays information on temperatures and sensors.
	Settings. Opens individual settings.
	Back. Takes you backwards in the menu.
	Left arrow. Allows you to scroll to the left through the menu settings.
	Right arrow. Allows you to scroll to the right through the menu settings.
	OK. Allows you to accept the selected option.
	Select. Allows you to select an option from the shown menu.
	Edit. Allows you to edit settings.
	Plus. Allows you to: Increase the value of the selected setting. Move to the next menu item. Move from a one-day view to a week view in the temperature, relative humidity of air and carbon dioxide level graphs.
	Minus. Allows you to: Reduce the value of the selected setting. Return to the previous menu item. Move from a week view to a one-day view in the temperature, relative humidity of air and carbon dioxide level graphs.
	Up arrow. Allows you to scroll upwards in the menu.
	Down arrow. Allows you to scroll downwards in the menu.
	Statistics. Allows you to open the temperature, relative humidity of air and carbon dioxide level graphs (1 day or 1 week).
	Indicate the chosen user level.
	Indicates when the feature is locked at your user level. The parental controls lock code is 1001.

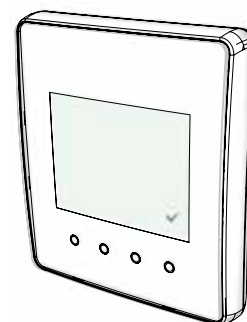

NOTE

The Adroit Digital Controller contains the buttons described in the following table. You can press the graphical user interface buttons by using the ring-shaped buttons below the controller. The controller panel does not have a touch screen.

INTRODUCTION

Ventilation has to be constant for the indoor air to stay healthy for the building's occupants. Even for longer holidays, it is not advisable to stop the ventilation because the indoor air will become stuffy and during the heating season, the indoor air humidity may condense in the ventilation ductwork and structures, causing moisture damage.

You can control and automate the ventilation unit operation in the following ways:

- By using a Digital Controller installed in the building
- Through the Adroit Home local network connection and the Web interface
- Through the Adroit Cloud Service and the Web interface
- Through a remote monitoring service or building automation system (BMS) by using voltage signals or Modbus messages

The required ventilation may also be adjusted automatically with the optional room mounted between carbon dioxide and humidity sensors. In this case, ventilation remains optimal even if the dwelling is unoccupied.

By using the week clock, you can create just the right ventilation for your individual lifestyle.



WARNING

The unit is not intended for use by children (under 8 years) or by persons with reduced sensory, physical, or mental capabilities, or lack of knowledge and experience that limit the safe operation of the unit.

These people can use the product under the supervision of a person responsible for their safety or as directed.



TIP

The Adroit Digital Controller automatically switches to sleep mode when the pre-set sleep time has elapsed. You can wake up the Adroit Digital Controller by pressing any control button.

INTRODUCTION

Each ventilation unit has two control settings available, basic and expert. The basic settings are:

- User interface language.
- Time and date.

The expert settings are:

- System administrator password. The installer has given you the system administrator password.
- Possible parental controls.
- Fan settings.
- User profile settings, such as the temperature.

Settings can be changed at a later date if required.

STARTING THE UNIT

If you are starting the ventilation unit for the first time or after any maintenance procedure, when the unit starts up, the diagnostic display will appear for a few seconds, until the At home profile main screen is opened.

If the unit is switched off from the controller, you can restart the ventilation unit by pressing any button on the controller.

We recommend that the latest version always to be used. Check and download the latest version at <https://www.airflowadroitcontrol.com/> either before or immediately after setup.

The current software version of the ventilation unit is shown on the controller display when the unit is connected to the mains or factory settings are restored. Alternatively, the current software version can be checked from the Unit information display of the Service menu.

UPDATING THE UNIT SOFTWARE

Disconnect the ventilation unit from the mains electrical supply or turn off the fuse.

Connect the computer to the digital controller of the ventilation unit using a USB MicroB connector. Start the ventilation unit. A USB sign will appear on the display of the controller. The controller cannot be used when it is connected to the computer.

Transfer the update file you have downloaded onto the ventilation unit. Copy the update file HSWUPD.BIN

(Please note! Do not alter the file name!) you have downloaded at the root of the controller (the controller will be displayed on your computer as a mass memory or a removable disk drive). When the file has uploaded onto the controller, remove the USB cable. Next, the controller will take a while to load the update. The controller will now start to load the update file onto the motherboard. This can take several hours. The controller will remain turned on, but it is recommended that the controller will not be used during that time. When the update is ready, the unit will restart automatically.

TURNING THE UNIT OFF

If you want to turn off the ventilation unit, proceed as follows:



1. Select **Settings > Turn unit off**.
2. Press the **OK** button.
3. The system asks for confirmation.
4. Press the **OK** button.
5. The ventilation unit has now been turned **Off**.



NOTE

The first launch of the unit may take a while, as the controller will format its software and verify that it has the latest software version.



NOTE

However, it is recommended that the ventilation be kept turned **ON** without disruptions.

Adroit® DV96 (Integral CO₂ Sensor)

INSTALLATION

WALL MOUNTING

Note the following before mounting:

- DV96 Should not be positioned in an area that falls below +10°C.
- Avoid mounting the unit on a hollow, echoing partition wall or on a bedroom wall. Taking sound transmission precautions is recommended.
- The minimum distance between the top of the unit and the finished ceiling surface is 30 mm. Note that during mounting the unit rises 10 mm higher than the final height.
- It is recommended that the unit is not positioned in sound sensitive areas unless some acoustic deadening measures are taken.

Mount the DV96 on the wall with a mounting bracket, as shown in the adjacent figure. Make sure that the unit is horizontally level after mounting.

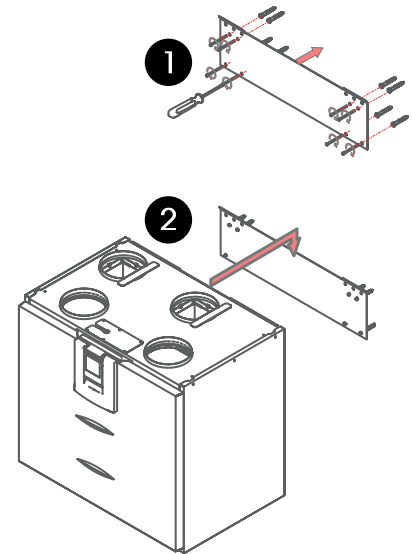

MEASURING TUBES

The accessory bag with the unit includes four airflow measuring tubes. These can be inserted in the ducts to allow for easier ventilation adjustment.

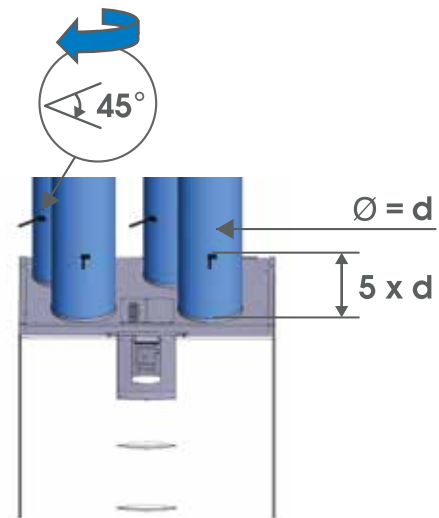
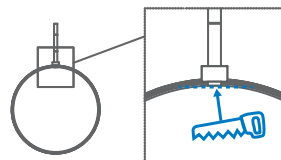
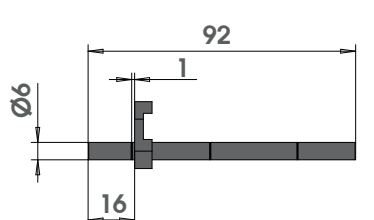

CEILING MOUNTING BY USING THE CEILING MOUNTING BRACKET

DV96 Adroit units can also be mounted vertically by using the optional ceiling mount bracket. Attach the ceiling mounting bracket:

- To the ceiling with M8 thread rods, connecting to suitable mount points that are strong enough to hold the weight of the unit.
- Horizontally level, as the plate determines the straightness of the unit.

Insulate the outdoor air and exhaust air duct against condensation, as well as between the unit and the ceiling mounting bracket.

NOTE

When installing the unit, please consider having sufficient space in front of the unit for servicing purposes.

DV96 Adroit:

The service space in front of the unit must be at least 400 mm deep.

Mount the ventilation unit in a place where the temperature does not fall below +10°C.

INSTALLATION

MOUNTING THE CEILING MOUNTING BRACKET

1. Attach the thread rods to the ceiling mounting points using the locking nuts to secure in place.
2. Lift the ceiling mounting bracket in place.
3. Push a rubber damper and a washer on each thread bar to the cup of the plate.
4. Turn the nuts to make sure that the unit is horizontally level.
5. Shorten the lower ends of the thread bars so that they will be at no more than 10 mm from the lower surface of the ceiling mounting bracket.

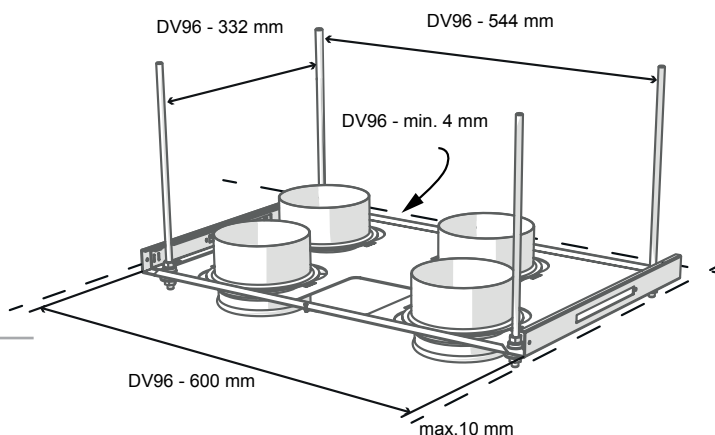

WARNING

The ventilation unit is very heavy. Do not perform this procedure alone.

MOUNTING THE VENTILATION UNIT TO THE CEILING MOUNTING BRACKET

1. Install the ceiling mounting bracket with M8 thread bars so that it is horizontally level.
2. Install the insulation washers into the outlet collars of the ventilation unit.
3. Remove the door before installing the ventilation unit to the ceiling mounting bracket.
4. Lift the ventilation unit close to the ceiling mounting bracket and feed the cables and the connection box through the hole in the ceiling mounting bracket on top of the ceiling.
5. Where required, the unit can be detached from the ceiling mounting bracket. Remove the door of the unit. Lift the unit slightly upwards and pull simultaneously from both operating levers (A) of the ceiling mounting bracket to detach the unit from the ceiling mounting bracket.



TIP

You can detach the unit from the ceiling mounting bracket by pulling the spring-loaded moulding to the direction shown by the arrow (more detailed information provided with the ceiling mounting bracket).

ATTIC FLOOR PENETRATION PLATE

The attic floor penetration plate (F) is optional. When an attic floor penetration plate is used, the tightness of the vapour barrier has to be ensured.

The minimum distance of the attic floor penetration plate from the rear wall is 5 mm. The minimum distance of the attic floor penetration plate from the side walls is 15 mm.



NOTE applies to 1.

The end of the thread bars must be 5 mm or less below the fastening nut. Do not fasten the ceiling mounting bracket too tight to the ceiling. Ensure that the sliding bars move and restore to their original position by pulling from the operating levers (A). The top edge of the white covering strip of the ceiling mounting bracket can be installed against the ceiling. Alternatively, a concealed mounting method can be used, in which case the ceiling can be 20 mm below the top of the white covering strip.



NOTE applies to 4.

Remember to make a service door in the ceiling so that the cables and the connection box can be accessed. The distance between the service door and the ceiling mounting bracket must be around 500 mm.

Alternatively, the cables can be fed between the ceiling mounting bracket and the ventilation unit to the rear wall. When the ventilation unit is lifted against the ceiling mounting bracket, the unit locks in place. Where needed, guide the mounting hooks on the ceiling mounting bracket (B) to the grooves on the side panels of the ventilation unit. There are operating levers (A) on the front bottom corners of the ceiling mounting bracket. When the levers have been restored to the same level with the white covering strip of the ceiling mounting bracket, the unit has been locked in place.

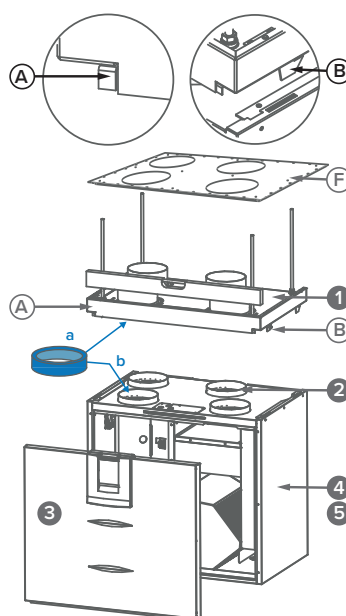

Adroit®

DV96 (Integral CO₂ Sensor)

INSTALLATION

CONDENSING WATER

In the heating season, the extract air humidity condenses into water. Water formation may be abundant in new buildings, or if the ventilation is low, compared to the humidity production of residents. Condensed water must be able to get out of the unit without obstruction. Check in conjunction with maintenance, for example, during the autumn before the heating season begins, that the condensate collection tray positioned inside the unit at its base is not clogged and that there is no leakage. You can check it by pouring a little water into the condensate collection tray positioned inside the unit at its base. Clean, if necessary. Water must not be allowed to enter the electrical system.

MOUNTING THE CONDENSING WATER OUTLET

1. Push the main body of the condensing water outlet downward from above, through the hole in the bottom plate of the ventilation unit.
2. Push the tension pin downward from below towards the main body.
3. Place the valve ball inside the housing of the condensing water outlet.
4. Attach the housing to the condensing water outlet.

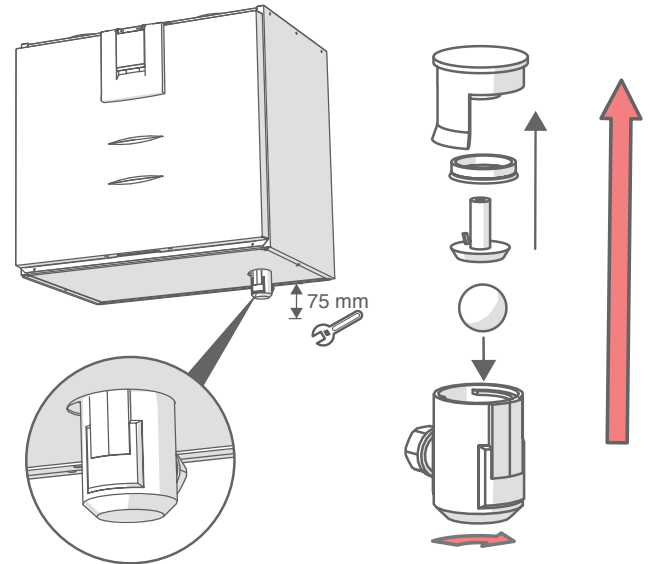

NOTE

The standard Silent Klick condensing water outlet installation requires 75 mm of free space below the ventilation unit.

INSTALLATION

CONDENSING WATER DIMENSIONS FIGURE

DV96

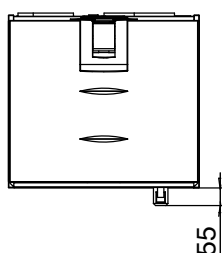
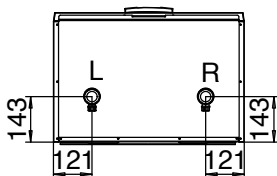

ALTERNATIVE WATER SEAL, WHICH CAN BE INSTALLED IN LOW SPACES



NOTE

If you use the alternative condensing water outlet, move the gasket ring and the locking part to the tube joint part that will be mounted on the wall.



NOTE

The alternative condensing water outlet installation requires 47 mm of free space below the ventilation unit.

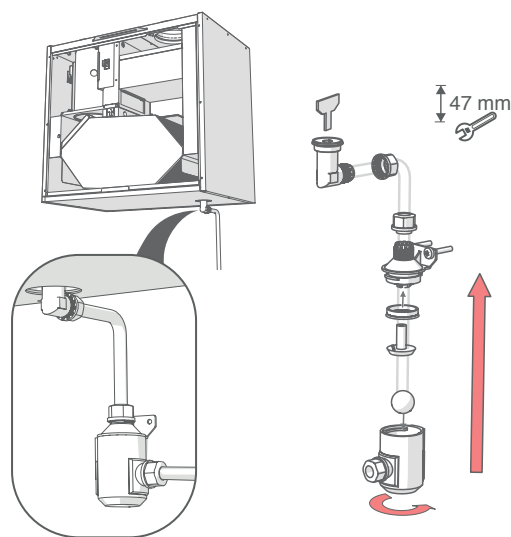

ALTERNATIVE WATER SEAL DIMENSIONS FIGURE

DV96

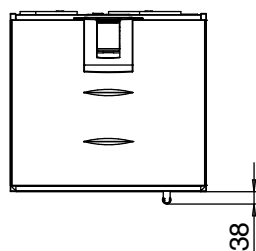

BEFORE BEGINNING MAINTENANCE WORK

When you open the device door, the safety switch (S) cuts the power. Despite this, the unit should be isolated from the power supply. Always isolate the unit from the power supply before starting the ventilation unit maintenance.

There are two unit models, left- (L) and right-handed (R). The figure shows the right-handed model.

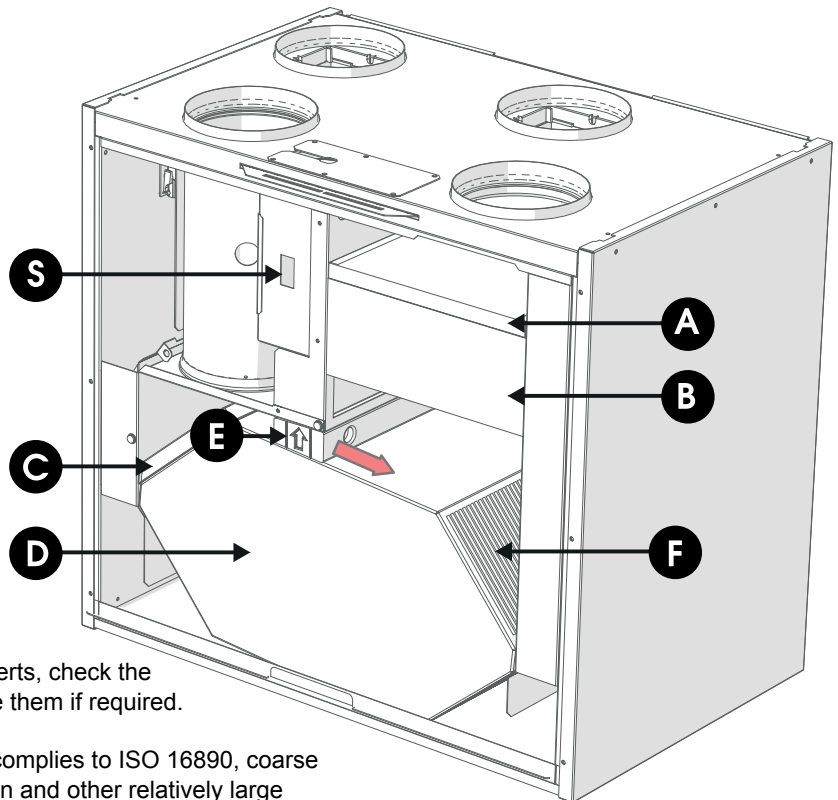

FILTERS

When the maintenance reminder alerts, check the cleanliness of the filters and replace them if required.

The Adroit unit has three air filters:

- 2 x ISO Coarse > 75% (G4) - complies to ISO 16890, coarse filter filters insects, heavy pollen and other relatively large foreign objects out of the outdoor air (A).
- 1 x ISO ePM1 50% (F7) filters - complies to ISO 16890 fine filter filters microscopic pollen and dust particles out of the supply air (B).
- The coarse filter filters the extract air and keeps the heat recovery cell clean (C).

The filter change interval depends on the ambient concentrations of dust and particulates. It is recommended that the filters be changed every spring and autumn, or at the very least once a year.



NOTE

DV96 Adroit:
 The service space in front of the unit must be at least 400 mm.



TIP

Using original Airflow filters ensures that the ventilation unit remains in top condition, giving the best results. The filter replacement interval depends on the ambient dust concentration.

It is recommended that the filters be replaced every spring and autumn or at the very least once a year. Failure to follow these recommendations may void any warranties.

MAINTENANCE INSTRUCTIONS

If you want to change the filters, proceed as follows:

1. Isolate the power to the ventilation unit.
2. Open the ventilation unit door by lifting the latch.
3. Lift the door off.
4. Remove the old filters (A, B, C) and discard them.
5. Install the new filters (A, B, C) in place.
6. Close the ventilation unit door. Make sure that the door safety switch penetrates the door switch and allows the unit to be switched on.
7. Reinststate the power to the unit.
8. The filters have now been changed.

HEAT RECOVERY CELL

Check that the heat recovery cells are clean every two years or whenever the filters are being changed.

To check the heat recovery cell, proceed as follows:

1. Isolate the power to the ventilation unit.
2. Open the ventilation unit door by lifting the latch up.
3. Lift the door off.
4. Remove the filters (A, B, C).
5. Remove the sealing strip (E) above the heat recovery cell in the direction of the arrow.
6. Lift and pull the heat recovery cell (D) out of the unit.
7. If the heat recovery cell is dirty, clean it by immersing it in warm water with a mild detergent.
8. Rinse the heat recovery cell clean with a water spray. Do not use a pressure washer.
9. When the water has drained from between the laminae, reassemble the ventilation unit in the reverse order.
10. When reassembling model DV96, check that the sealing strip below the heat recovery cell is pressed against the bottom of the unit.
11. Close the door. Make sure that the door safety switch penetrates the door switch and allows the unit to be switched on.
12. The heat recovery cell has now been checked and cleaned.



WARNING

Handle the heat recovery cell carefully! Do not handle the heat recovery cell by its thin membrane airflow dividers, as they can be easily damaged.

FANS

Check the cleanliness of the fans when carrying out the filters and heat recovery cell maintenance. Clean the fans, if necessary.

You can clean the fan blades with compressed air or by brushing them gently. Do not remove or move the fan blade balancing pieces.



WARNING

The fans can be easily damaged and should be handled carefully. We recommend that you clean the fans in place where they are mounted.

CLEANING THE SUPPLY AIR FAN

When you want to clean the supply air fan, proceed as follows:

1. Isolate the power to the ventilation unit.
2. Open the ventilation unit door by lifting the latch up.
3. Lift the door off.
4. As described in the Filters and Heat Recovery Cell section remove the extract air filter (C), the cell top bracket (E) and the heat recovery cell (D).
5. Pull out the temperature sensor (figure 1) located at the top of the extract air duct (G). Remove the stopper screw (I) at the bottom of the duct. The extract air duct is now loose and can be pushed down. This is done by pushing down and twisting at the same time. (figure 2).

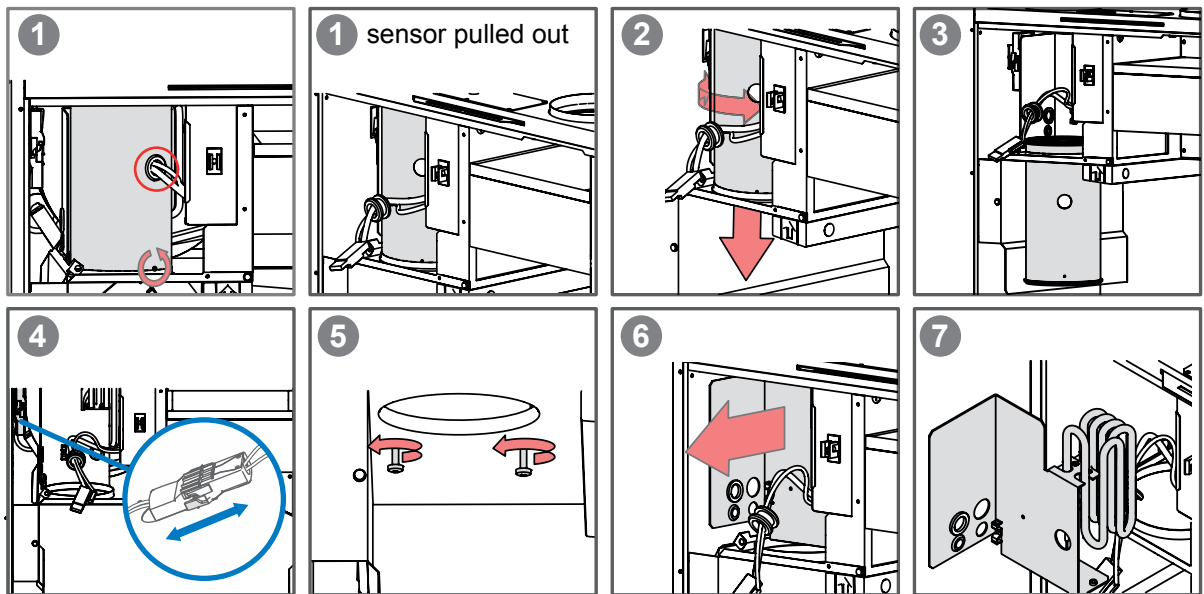
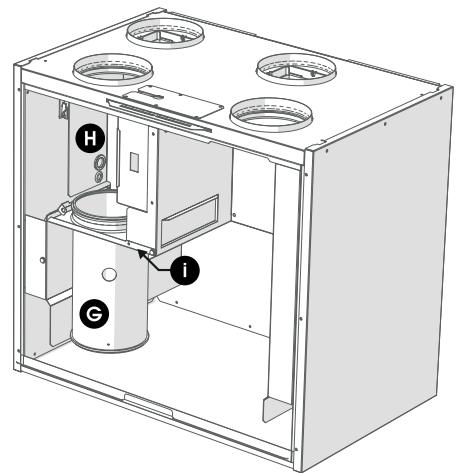

MAINTENANCE INSTRUCTIONS

6. Remove the temperature sensor from the post-heater support (figure 4).
7. If installed, remove the post-heater support, which is attached by two screws from below (figure 5).
8. Pull the post-heater and the support out of the unit (figures 6 and 7) and use the electrical connector to disconnect off the radiator wires. (figure 4).

! WARNING

Make sure that the heater is not hot before you pull it out of the unit.

9. The fan can now be cleaned in place. We recommend that you clean the fans in place.
10. If you want to remove the fan for cleaning, proceed as follows
 - a. If necessary, remove the arm pins. Use pliers to press the pins straight, so that they are easier to install back later.
 - b. Push the fan gently upwards (figure 9).
 - c. Pry the plastic lock to the right of the fan with, for example, a screwdriver (figure 10).
 - d. The fan falls down.
 - e. Pull the fan out of the unit (figure 11).
 - f. Disconnect the fan wire quick connector (figure 12). The fan has now been removed for cleaning.
11. Reassemble the ventilation unit in the reverse order.

i TIP

When you re-install the temperature sensor, install it with the tip upward in such a way that it does not get squeezed between the bypass plate, and that it does not lean against the post-heater frame.

12. Close the door and reconnect the unit back into the mains.
13. The fan has now been checked and cleaned.

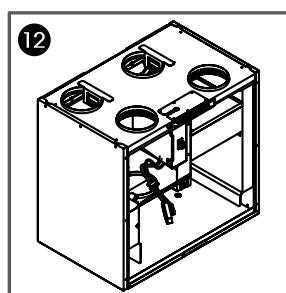
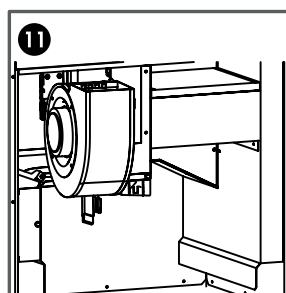
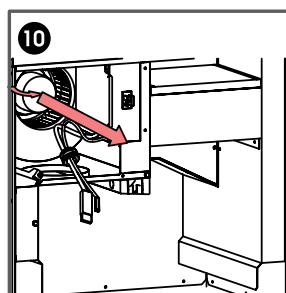
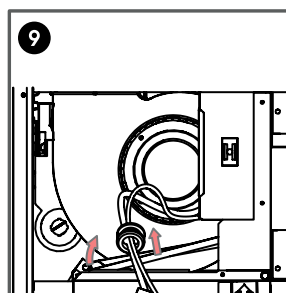
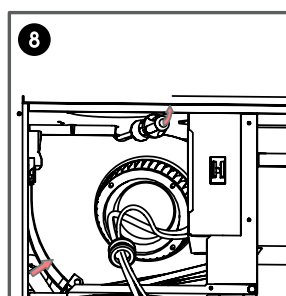

CLEANING THE EXTRACT AIR FAN

When you want to clean the extract air fan, proceed as follows:

1. Isolate the power to the ventilation unit.
2. Open the ventilation unit door by lifting the latch.
3. Lift the door off. Please note that the door is heavy.
4. Remove the filters, the cell top support and the heat recovery cell, as described in sections Filters and Heat Recovery Cell.
5. Open the four screws (PZ2) (figure 1) on the extract air fan cover and remove the cover (figure 2).
6. The fan can now be cleaned in place.
7. If you want to remove the fan for cleaning, proceed as follows.
 - a. Push the fan gently upward (figure 3).
 - b. Pry the plastic lock to the right of the fan with a suitably sized screwdriver. (figure 4).
 - c. The fan is now released and will drop down. (figure 5)
 - d. Pull the fan out of the unit.
 - e. Disconnect the fan wire quick connector (figure 6).
8. Carefully clean the fan with a soft brush.
9. Reassemble the ventilation unit in the reverse order.
10. Close the door and reconnect the unit back into the mains.
11. The extract air fan has now been checked and cleaned.

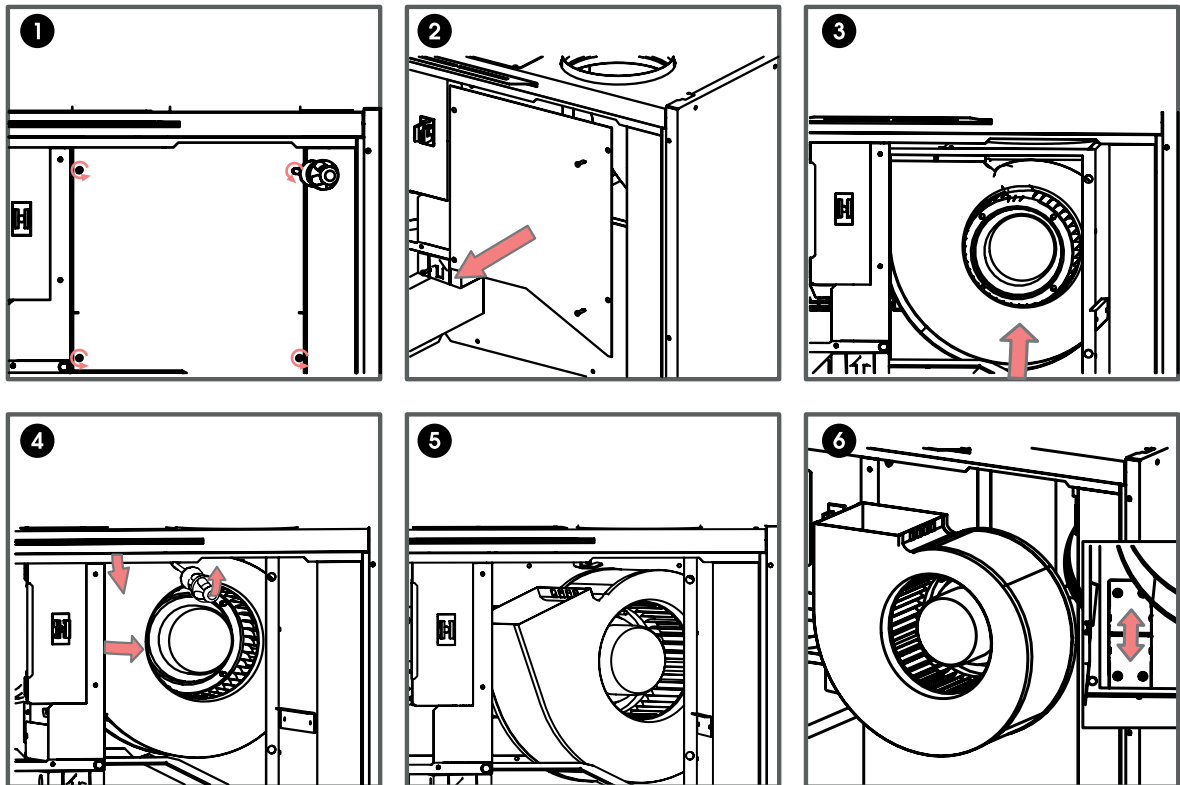

MAINTENANCE INSTRUCTIONS

CONDENSING WATER

In the heating season, the extract air humidity condenses into water. Water formation may be abundant in new buildings, or if the ventilation is low, compared to the humidity production of residents. Condensed water must be able to get out of the unit without obstruction. The condensation drain and pipe should be checked and cleaned if necessary, in conjunction with maintenance, for example, during the autumn before the heating season begins. Check the water condensate collection tray, positioned inside the unit at its base to ensure it is not clogged and that there is no leakage. You can check this by pouring a little water into the condensate collection tray. Clean, if necessary. Check the condensing water outlet connection is secure.



NOTE

There may be some water in the condensed water tray at the bottom of the unit. This is normal, and requires no actions from you.



WARNING

Water must not be allowed to enter the electrical system.

TROUBLESHOOTING

The table below contains troubleshooting and fault repair instructions.

FAULT	CAUSE	MEASURES
Message on the user interface: Extract fan stopped	The extract air fan has stopped.	Make sure that the fan is not running. The fan cabling and operation must be checked, and if necessary, the fan must be replaced. Contact the service centre.
Message on the user interface: Supply fan stopped	The supply air fan has stopped.	Make sure that the fan is not running. The fan cabling and operation must be checked, and if necessary, the fan must be replaced. Contact the service centre.
Message on the user interface: Heat recovery cell has frozen	The heat recovery cell has become excessively cold.	Conduct a manual defrost through the controller (Service menu > Cell defrost). Try to discover why the heat recovery cell is frozen.
Message on the user interface: Temperature sensor 1/2/3/4/5	The temperature sensor indicated on the user interface is damaged.	The sensor installation must be checked, and if required, the sensor must be replaced. Contact the service centre.
Message on the user interface: External sensor	The external temperature sensor is damaged.	The sensor installation must be checked, and if required, the sensor must be replaced. Contact the service centre.
Message on the user interface: Post-heater	The post-heater does not heat.	The heater installation must be checked, and if required, the heater must be replaced. Contact the service centre.
Message on the user interface: Bus fault	Problems with the data transfer bus.	Make sure that the Modbus bus is connected correctly, and that the devices connected to it are properly functioning.
The ventilation unit is not working; the controller is not working.	Power input to the unit is lost.	Check: • Fuse in the fusebox • Fuse in the unit • Check isolation switch is in the ON position.
The ventilation unit is working, but the controller is not working.	Either the controller 24 VDC power is lost, or the controller is damaged.	Check the cables from the unit to the controller. Contact the service centre if necessary.

Adroit® DV96 (Integral CO₂ Sensor)

TECHNICAL SPECIFICATIONS DV96

TECHNICAL SPECIFICATIONS

Product codes DV96 (R) Adroit (Integral CO ₂ Sensor) DV96 (L) Adroit (Integral CO ₂ Sensor)	Product number 90001265 90001265EPH 90001266 90001266EPH		
Air volumes Supply Air Extract Air	81 l/s, 291m ³ /h, 100 Pa 86 l/s, 310m ³ /h, 100 Pa	Fans	0.119kW, 0.9A EC 0.119kW, 0.9A EC
Electrical connection	230V, 50Hz 5.1A	Operating efficiencies	Annual efficiency Supply air efficiency Specific Fan Power (SFP) 77% A+ 86% 1.4 W/(l/s)
Enclosure protection class	IP 34	Filter class (ISO 16890)	Supply Air Extract Air ISO Coarse > 75% (G4) and ISO ePM1 (F7) ISO Coarse > 75% (G4) - ISO 16890 compliant
Optional post-heater	Power, 900 W	Heat recovery bypass	Automatic
Dimensions (w x h x d)	600 x 545 x 428 mm	Weight	47 kg

FAN INPUT POWER SUPPLY / EXTRACT AIR VOLUMES

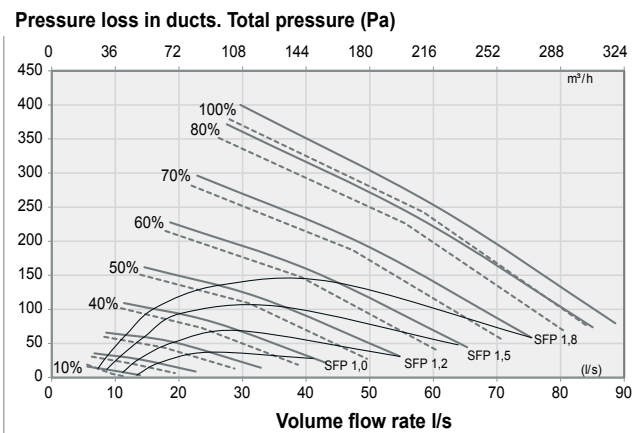
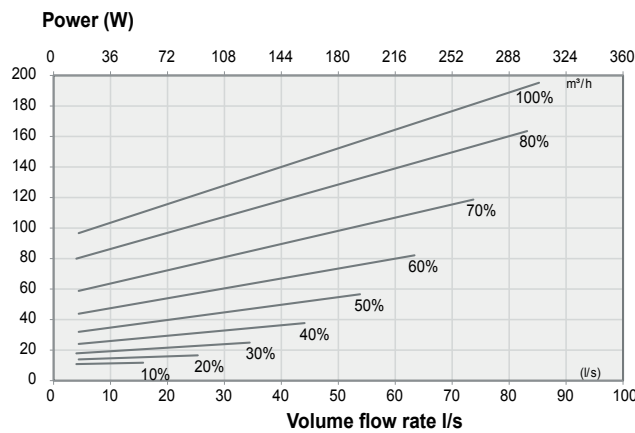

$$SFP = \frac{\text{Input power (total) (W)}}{\text{Air flow (max)}}$$

SFP rate (Specific Fan Power) recommended value <1.8 (kW m³/s)

— extract air
- - - supply air

SOUND VALUES

Adjustment position (%)	Sound power level in the supply air duct (one duct) by octave band Lw, dB									Sound power level in the extract air duct (one duct) by octave band Lw, dB								
	Adjustable position									Adjustable position								
	10	20	30	40	50	60	70	80	100	10	20	30	40	50	60	70	80	100
63	54	63	69	74	76	80	84	87	86	51	55	63	66	70	73	76	78	79
125	50	56	62	66	70	73	77	80	81	43	46	52	55	60	63	66	68	71
250	46	54	59	63	66	69	72	74	77	33	38	44	47	51	55	58	61	63
500	40	48	54	57	61	63	66	68	71	29	38	44	47	51	53	57	59	61
1000	34	44	51	55	60	62	64	66	68	23	32	38	42	46	49	52	54	57
2000	21	35	44	49	54	57	61	63	66	13	17	24	29	33	36	39	42	44
4000	17	23	34	41	47	51	55	58	61	17	17	18	20	23	26	29	32	34
8000	21	21	26	34	42	47	52	56	59	21	21	21	21	21	22	23	25	27
LW, dB	56	65	70	75	78	81	85	88	88	52	56	64	66	71	74	76	79	80
LWA, dB(A)	42	50	57	61	64	67	70	73	75	33	39	45	48	52	55	58	61	63
Sound pressure level coming through the envelope of the unit in the room in which it is installed (10m ² sound absorption)																		
Adjustable position																		
Adjustment position (%)	10	20	30	40	50	60	70	80	100	10	20	30	40	50	60	70	80	100
LpA, dB (A)	24	28	34	33	38	41	44	46	48	24	28	34	33	38	41	44	46	48

MAIN PARTS

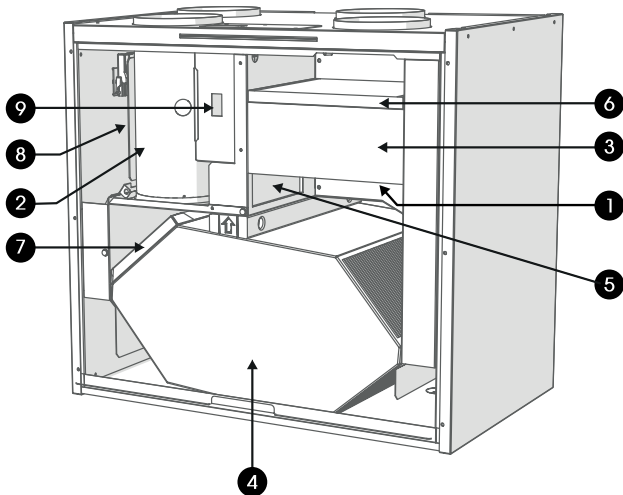

Model R in the figure.
In the L model, the parts are mirrored

- | | |
|---|---|
| <ul style="list-style-type: none"> 1 Extract air fan (behind the protective cover) 2 Supply air fan (behind the extract air duct) 3 Outdoor air filter ISO ePM1 50% (F7) 4 Heat recovery cell | <ul style="list-style-type: none"> 5 Summer/winter damper 6 Outdoor air filter ISO Coarse > 75% (G4) 7 Extract air filter ISO Coarse > 75% (G4) 8 Optional post-heater (behind the extract air duct) 9 Safety switch |
|---|---|

MEASUREMENT POINTS

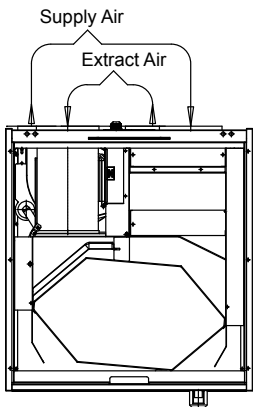

Measurement points after the connection outlet.
The fan curves indicate the total pressure accounted for by duct losses.

DIMENSIONS AND DUCT OUTLETS

Dimensions

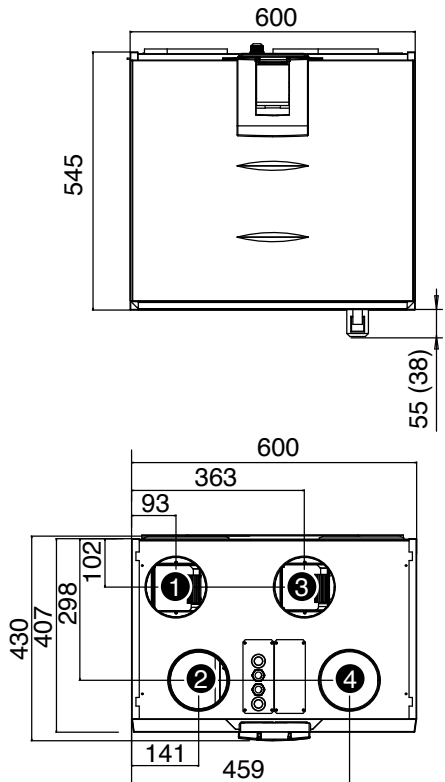

DUCT OUTLETS

Model R

Inner diameter of the female collar: $\varnothing 125$

- 1. Supply air from the unit to the apartment
- 2. Extract air from the apartment to the unit
- 3. Exhaust air flowing outdoors from the unit
- 4. Outdoor air to the unit

Model L

Inner diameter of the female collar: $\varnothing 125$

- 1. Exhaust air flowing outdoors from the unit
- 2. Outdoor air to the unit
- 3. Supply air from the unit to the apartment
- 4. Extract air from the apartment to the unit

Adroit[®] DV96 (Integral CO₂ Sensor)

INTERNAL ELECTRICAL CONNECTION DV96

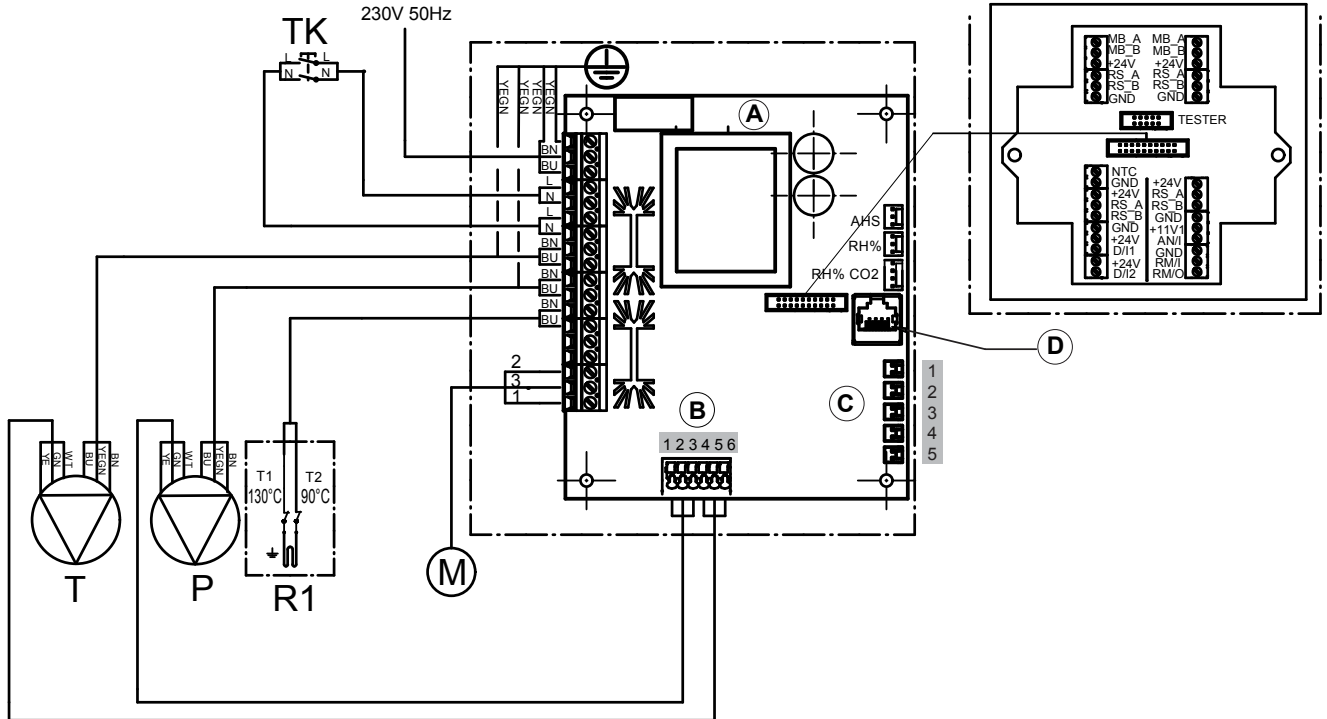

A	Motherboard
B	1. Extract air fan tacho (WT) 2. GND (GN) 3. Extract air fan PWM (YE) 4. Supply air fan tacho (WT) 5. GND (GN) 6. Supply air fan PWM (YE)
C	1. Extract air 2. Outdoor air 3. Supply air 4. Exhaust air 5. Supply air from the HR cell
D	LAN

MB_A	External Modbus A signal
MB_B	External Modbus B signal
+24V	+24V voltage (DC)
GND	Digital and analog ground potential
RS_A	Local hardware Modbus A signal
RS_B	Local hardware Modbus B signal
NTC	External temperature sensor connector
D/I1	Digital input 1
D/I2	Digital input 2
11V1	11.1 V operating voltage
AN/I	Analog input 0-10VDC
RM/I	24V relay input
RM/O	24V relay output

T	Supply air fan
P	Extract air fan
M	Damper motor
TK	Safety switch
AHS	Post-heating control
S/E	Fan balance adjustment
RH%	Internal humidity sensor
RH% CO ₂	Internal humidity sensor
R1	Post-heating resistor with 90°C and 130°C overheating protection

CABLE COLOURS

BK	Black
BU	Blue
BN	Brown
WT	White
GY	Grey
YE	Yellow
YEGN	Yellow-green

Adroit® DV96 (Integral CO₂ Sensor)

EXTERNAL ELECTRICAL CONNECTION FOR BRINE HEAT EXCHANGER

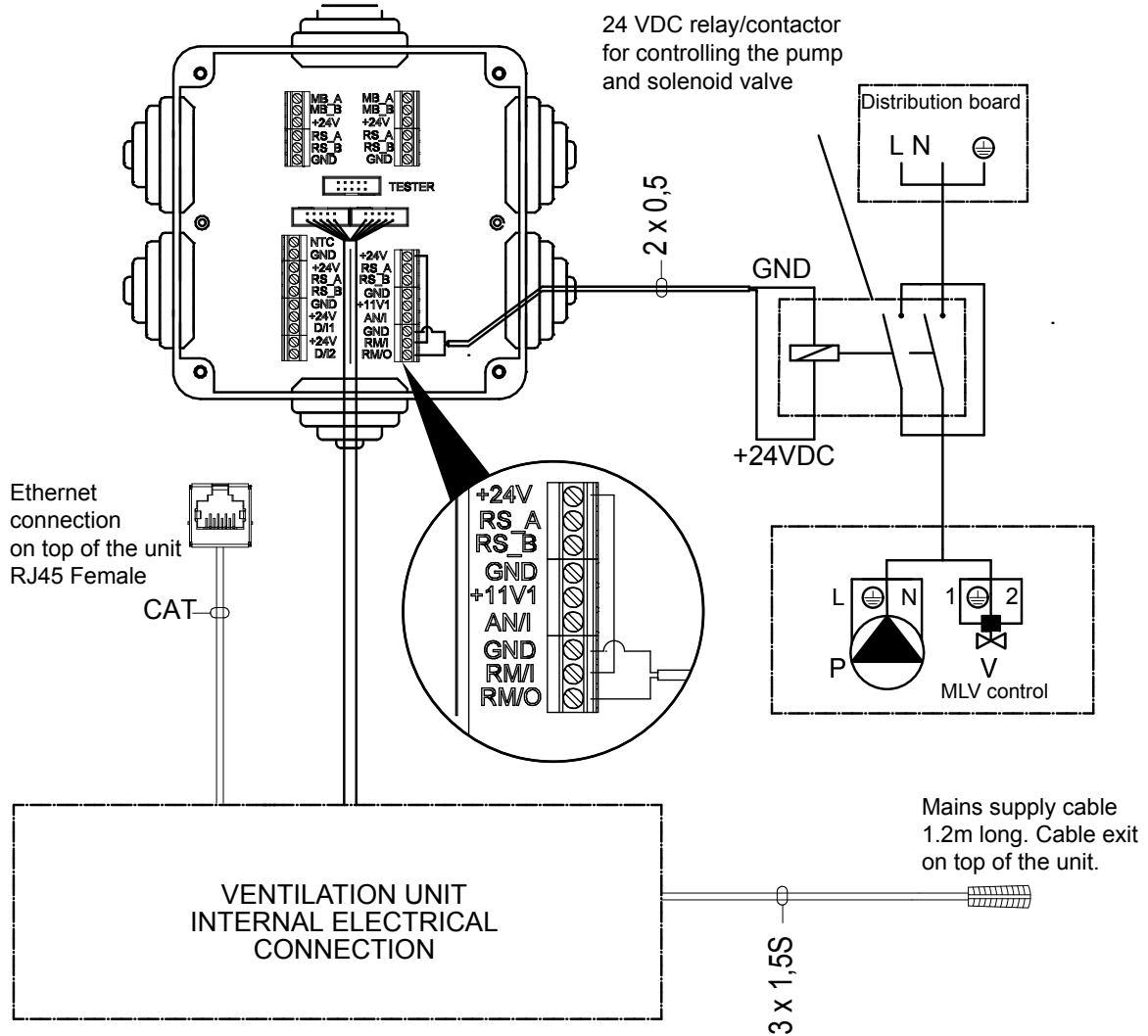

+24V	+24V voltage (DC)
GND	Digital and analog ground potential
RS_	Local hardware Modbus A signal
RS_B	Local hardware Modbus B signal
11V1	11.1 V operating voltage
AN/I	Analog input 0-10VDC
RM/I	24V relay input
RM/O	24V relay output
P	Circulation pump
V	Solenoid valve

EXTERNAL ELECTRICAL CONNECTION DV96

Adroit® DV96 (Integral CO₂ Sensor)

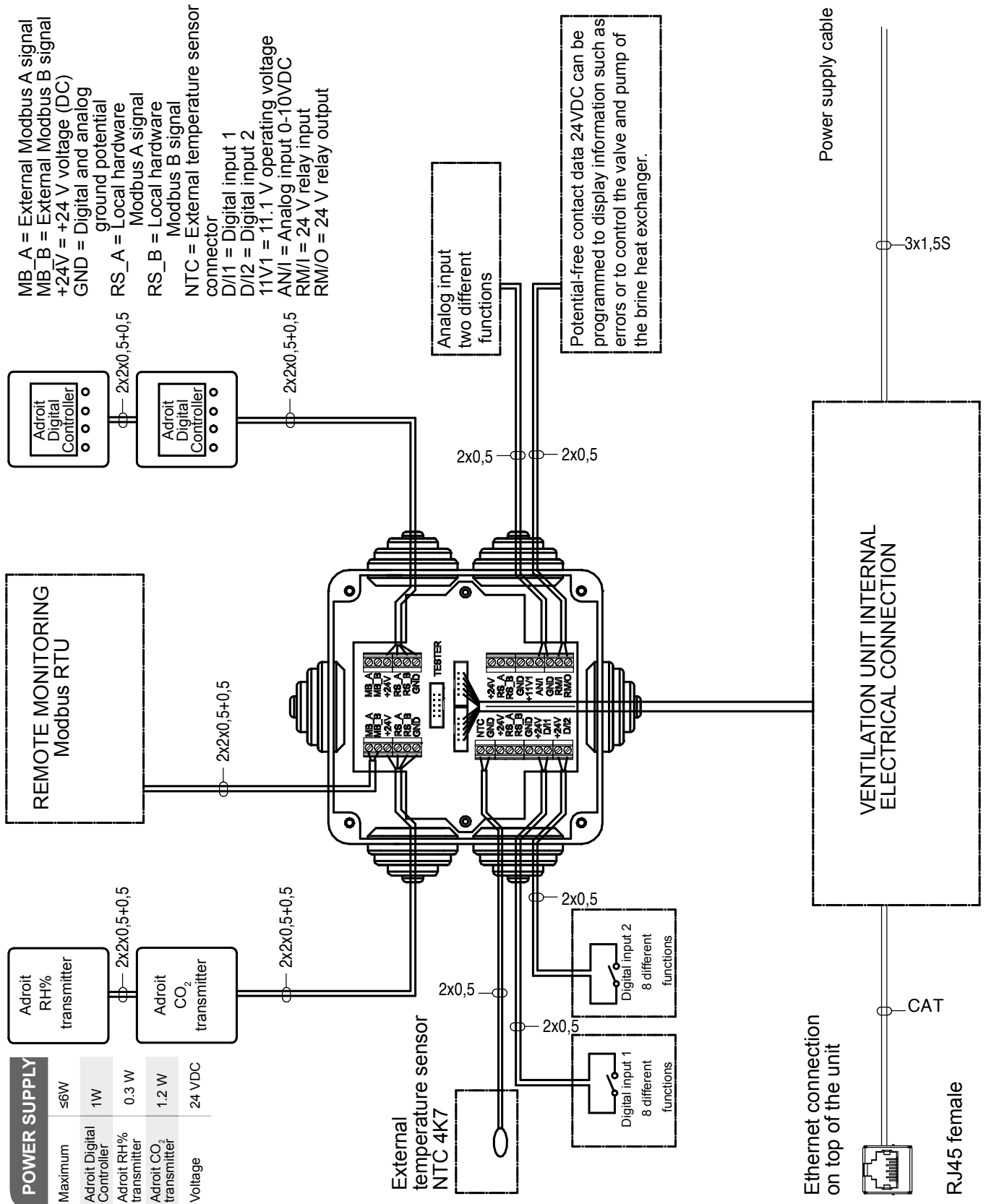



CE DECLARATION OF CONFORMITY

Airflow Developments Ltd, herewith declare that the air movement equipment designated below, on the basis of its design and construction in the form brought onto the market by us in accordance with the relevant safety and health requirements of the EC directive on Low Voltage.

Designation of Equipment: Mechanical Ventilation with Heat Recovery

Relevant EC council directives:

- 2014/35/EU** Low Voltage Directive
- 2014/30/EU** Electromagnetic Compatibility (EMC) Directive
- 2011/65/EU** Restriction on the use of hazardous substances (RoHS) Directive
- 2006/42/EU** Machinery Directive

Applied Harmonised standards:

- EN ISO 12100-1:2003+A1:2009** Safety of machinery. General principles for design. Risk assessment and risk reduction
- BS EN 61000-6-4:2007+A1:2011** Electromagnetic compatibility (EMC). Generic standards. Emission standard for industrial environments
- BS EN 60335-1:2012+A11:2014** Household and similar electrical appliances. Safety. General requirements
- BS EN ISO 13732-1:2008** Ergonomics of the thermal environment. Methods for the assessment of human responses to contact with surfaces. Hot surfaces
- BS EN ISO 3746:2010** Acoustics. Determination of sound power levels and sound energy levels of noise sources using sound pressure. Survey method using an enveloping measurement surface over a reflecting plane

Applied National Standards and Technical Specs. In Particular Basis of self-attestation:

- Quality Assurance** BS EN ISO 9001/2015 – Cert no – FM 00152
- Environmental Assurance** BE EN ISO 14001/2015 – Cert No – EMS 569454

Any alterations or modifications made to the equipment, without prior consultation with Airflow Developments Ltd, invalidates this declaration.

Name: Alan Siggins **Date:** 10/06/2019
Position: Managing Director

Airflow Developments Limited
Aidelle House, Lancaster Road, Cressex Business Park
High Wycombe, Buckinghamshire. HP12 3QP, U.K.
T: +44 (0)1494 425252
E: info@airflow.com W: airflow.com



UKCA DECLARATION OF CONFORMITY

Airflow Developments Ltd, herewith declare that the air movement equipment designated below, on the basis of its design and construction in the form brought onto the market by us in accordance with the relevant safety and health requirements of the EC directive on Low Voltage.

Designation of Equipment: Mechanical Ventilation with Heat Recovery**Relevant EC council directives:**

2016 No.1101	The Electrical Equipment (Safety) Regulations 2016
2016 No.1091	The Electromagnetic Compatibility Regulations 2016
2012 No.3032	The Restriction of the Use of Certain Hazardous Substances in Electrical and Electronic Equipment Regulations 2012
2008 No.1597	The Supply of Machinery (Safety) Regulations 2008

Applied Harmonised standards:

EN 12100-1:2003+A1:2009	Safety of machinery. General principles for design. Risk assessment and risk reduction
BS 61000-6-4:2007+A1:2011	Electromagnetic compatibility (EMC). Generic standards. Emission standard for industrial environments
BS 60335-1:2012+A11:2014	Household and similar electrical appliances. Safety. General requirements
BS ISO 13732-1:2008	Ergonomics of the thermal environment. Methods for the assessment of human responses to contact with surfaces. Hot surfaces
BS ISO 3746:2010	Acoustics. Determination of sound power levels and sound energy levels of noise sources using sound pressure. Survey method using an enveloping measurement surface over a reflecting plane

Applied National Standards and Technical Specs. In Particular Basis of self-attestation:

Quality Assurance	BS ISO 9001/2015 – Cert no – FM 00152
Environmental Assurance	BS ISO 14001/2015 – Cert No – EMS 569454

Any alterations or modifications made to the equipment, without prior consultation with Airflow Developments Ltd, invalidates this declaration.

Name: Alan Siggins

Date: 10/06/2019
Position: Managing Director

Airflow Developments Limited
Aidelle House, Lancaster Road, Cressex Business Park
High Wycombe, Buckinghamshire. HP12 3QP, U.K.
T: +44 (0)1494 425252
E: info@airflow.com W: airflow.com

**EXPLODED VIEW AND PARTS LIST
DV96**

**Adroit®
DV96 (Integral CO₂ Sensor)**

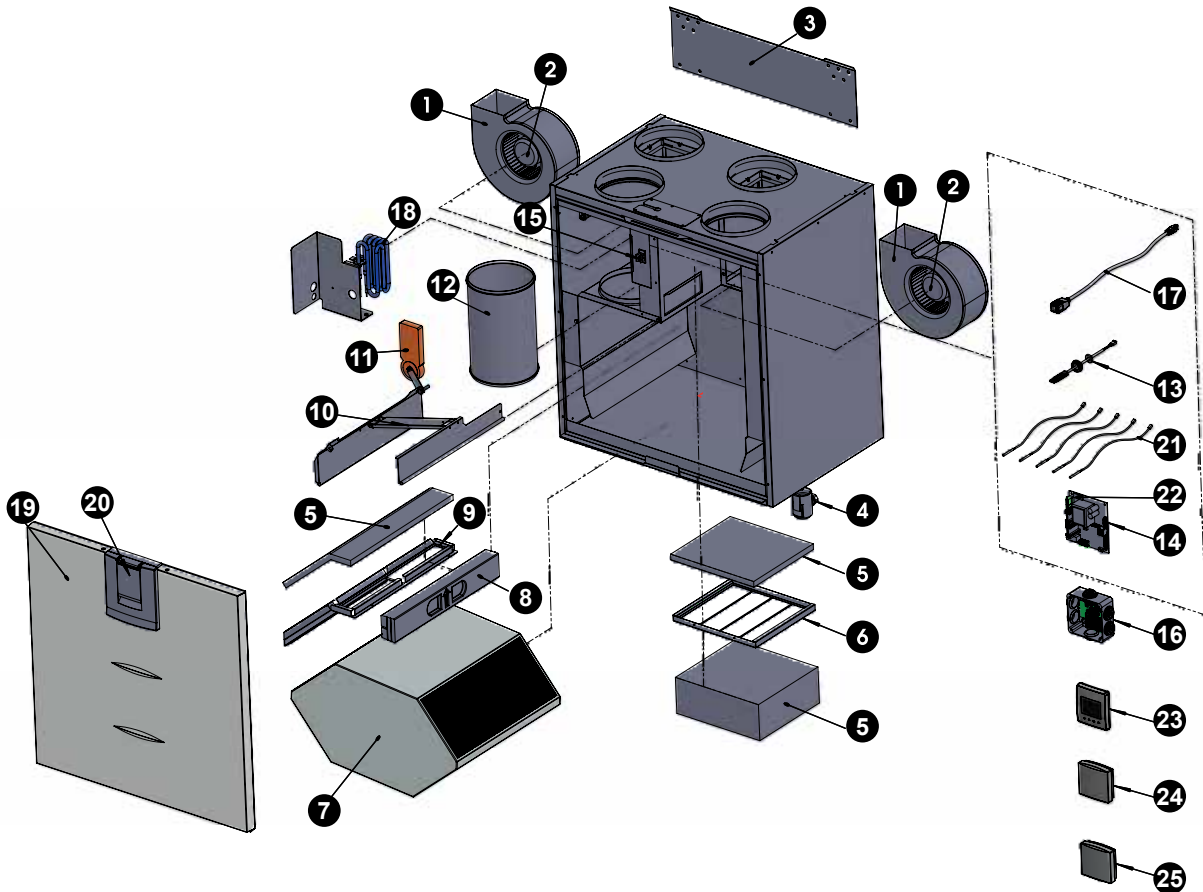

NO.	PART	CODE	NO.	PART	CODE	NO.	PART	CODE
1.	Fan assembly (with housing)	60000129	10.	The bypass duct assembly		18	Post-heater 900W (Optional)	
2.	Fan motor (without housing)	60000210		Right hand model	60000221		Right hand model	60000131
				Left hand model	60000222		Left hand model	60000132
3.	Wall mounting bracket	60000241	11.	Bypass damper motor	60000205	19.	Door assembly	60000196
4.	Condensation drain kit	60000250	12.	Extract air outlet	60000225	20.	Door latch assembly	60000224
5.	Filter set 2x ISO Coarse > 75% (G4) and 1x ISO ePM1 (F7)	90000375	13.	Internal humidity and CO ₂ sensor	60000591	21.	NTC sensor (1pc.)	60000134
6.	Outdoor air ISO Coarse > 75% (G4) filter stand	60000237	14.	Adroit motherboard	60000581	22.	Glass tube fuse 5 x 20, 80 mA, slow	60000231
7.	HR cell	60000232	15.	Safety switch	60000135	23.	Adroit Digital Controller (optional)	90000610
8.	Upper support for HR cell	60000243	16.	Connection box	60000208	24.	Adroit Humidity Transmitter (optional)	90000612
9.	Extract air ISO Coarse > 75% (G4) filter stand	60000228	17.	RJ45 extension cable	60000209	25.	Adroit CO ₂ Transmitter (optional)	90000613

Adroit® DV96

COMMISSIONING THE SYSTEM

The Building Regulations 2010, Statutory Instrument Part 9, paragraph 42, imposes a requirement that testing and reporting of mechanical ventilation performance is conducted in accordance with an approved procedure.

Compliance with this requirement by an assessed and registered “Competent Person” should follow a “Best Practice” process and adopt air flow measurement, Method A - The Unconditional Method - using a suitable UKAS certified measuring instrument. Generically referred to as a “Zero Pressure Air Flow Meter” or “Powered Flow Meter”.

Further information on this method is detailed in NHBC Building Regulations Guidance Note G272a 10/13 and BSRIA “A Guide to Measuring Air Flow Rates” document BG46/2015

WARRANTY

Applicable to units installed and used within the United Kingdom. Airflow Developments Ltd guarantees the DV96 Adroit unit for 5 YEARS from date of purchase against faulty material or workmanship. Motors are only covered for 1 YEAR from date of purchase against faulty material or workmanship.

In the event of any defective parts being found, Airflow Developments Ltd reserve the right to repair, or at our discretion, replace without charge provided that the unit:

- Has been installed and used in accordance with the fitting and wiring instructions supplied with each unit.
- Has not been connected to an unsuitable electrical supply.
- Has not been subjected to misuse, neglect or damage.
- Has not been modified or repaired by any person not authorised by Airflow Developments Ltd.
- Has been installed in accordance with latest Building Regulations and IEEE wiring regulations by a recognised competent installer.

Airflow Developments Ltd shall not be liable for any loss, injury or other consequential damage, in the event of a failure of the equipment or arising from, or in connection with the equipment, excepting only that nothing in this condition shall be construed as to exclude or restrict liability or negligence.

This warranty does not in any way affect any statutory or other consumer rights.



Call: 01494 525252

Visit: airflow.com

80001117 - Issue 3 02/24



Airflow Developments Limited
Aidelle House, Lancaster Road,
Cressex Business Park,
High Wycombe, Buckinghamshire,
United Kingdom, HP12 3QP

E-mail: info@airflow.com
Telephone: +44 (0) 1494 525252

airflow.com

© Airflow Developments Limited. Airflow Developments Limited reserve the right, in the interests of continuous development, to alter specifications without prior notice. All orders are accepted subject to our conditions of sale which are available on request

